

# TC-FLT SERIES ACID NEUTRALIZING WATER TREATMENT SYSTEM

(Generation 6 of Controls)



*Rain Soft*

Part No. 50034  
Rev C 09/24

## TABLE OF CONTENTS

---

Application Limitations . . . . .	3
Operational Specifications . . . . .	3
Product Certification Information. . . . .	4
Installation Instructions. . . . .	4-7
System Start Up . . . . .	7
Maintenance Requirements . . . . .	8
An Overview of the Regeneration Process . . . . .	8
TC Display . . . . .	9
TC Control Navigation . . . . .	9
Regeneration Settings . . . . .	9
Installer Mode . . . . .	10
System Errors . . . . .	10
System Testing . . . . .	10
Troubleshooting Guide . . . . .	11
Exploded Views and Parts Lists . . . . .	12-13
Warranty Information . . . . .	14
Installer Specification Sheet . . . . .	15

## Congratulations on your purchase of a RainSoft water treatment system.

This Owner's Manual is designed to assist with the operation, maintenance, and installation of your TC Filter system. It is our sincere hope that this manual is clear, concise, and helpful to you as a new owner.

**Questions?** If you have any questions regarding the installation, operation, or servicing of this system, please contact your local RainSoft Dealer. Your local RainSoft Dealer is familiar with your particular water conditions, and is able to address your concerns promptly and efficiently.

## APPLICATION LIMITATIONS

---

- Hardness levels should not exceed five (5) grains per gallon. Please see the Important Note on the right for more details.
- The well pump flow rate must exceed 6 gallons per minute. Failure to properly backwash the system at a rate of six (6) gallons per minute will inhibit the filter's ability to perform as designed.
- Service flow rates that exceed six (6) gallons per minute may cause the system not to function as designed. To avoid the possibility of excessive water use, do not use multiple faucets at the same time.
- Your untreated water quality may change over time. Changes in your untreated water quality that exceed the system's capabilities, may require the use of additional equipment. If a change in the quality of your untreated water has occurred, please contact your RainSoft Dealer immediately.
- If you live in an area that has severe climate changes from summer to winter, you may notice a change in the operating performance of the system. Please contact your RainSoft Dealer for further recommendations.

## OPERATIONAL SPECIFICATIONS

---

Plumbing:	3/4 inch to 1 1/4 inch I.D.
Drain Line:	1/2 inch I.D.
Water Pressure:	20 psi – 120 psi (1.38 bar – 6.89 bar)
Operating Temperature:	40 – 100°F (4.4 – 37.8°C)
pH	5.0 - 7.0: Models TC-FLT 100P Y and TC-FLT 150P Y 4.5 - 6.0: Models TC-FLT 100P YZ and TC-FLT 150P YZ

### Electrical Requirements

A properly grounded alternating current supply (110 VAC 60 Hz or 230 VAC 50 Hz) is required for the operation of this system. Please check the power supply for the correct voltage requirements.

### Bypass Valve

The bypass valve enables you to bypass the system in situations of emergency leaks in the equipment, service calls.

### Existing Plumbing Conditions

Plumbing should be free from lime and/or iron buildup. Piping that contains large amounts of lime and/or iron should be replaced.

### Additional Specifications

- Do not install this system where water is microbiologically unsafe or of unknown quality without adequate disinfection before or after the system.
- This system must be installed in accordance with all applicable state and local laws and regulations.
- The Commonwealth of Massachusetts Plumbing Code 248 CMR shall be adhered to. A licensed plumber shall be used for this installation.
- This system must be installed in an area not affected by extreme heat, cold or the elements. The selected installation area must be adequate for easy service and accessibility.
- This system is designed to treat cold water only. The installation must be on a cold water supply.

**Important Note:** This system may be installed on well water or municipality treated water supplies.

**Important Note:** Water pressure of a minimum of 30 PSI (2.07 bar) is recommended for systems using 10" Diameter tanks to achieve proper backwash flow rate.

**Important Note:** This system requires the use of the included power supply (24 VDC).

**Important Note:** The manually operated bypass valve enables the conditioner to be isolated from the water service line for maintenance and service. It also maintains the continuity of the water supply when the conditioner is disconnected.

**Important Note:** For Massachusetts Residents Only: The Commonwealth of Massachusetts Plumbing Code 248 CMR shall be adhered to. A licensed plumber shall be used for this installation.

## PRODUCT CERTIFICATION INFORMATION

Water treatment devices sold to retail consumers in California, accompanied by certain health claims, must be registered by the California State Water Resources Control Board. This product is not certified in the State of California for the purpose of making health claims.

## INSTALLATION INSTRUCTIONS

### 1. Safety Precautions

- To prevent an accident and/or injury, do not hoist the unit over your shoulder. Use a hand truck to transport the unit.
- Do not lay the unit on its side.
- Wear safety glasses and work gloves during installation.

### 2. Test the Raw Water

- If water contains iron, manganese or hydrogen sulfide, a separate iron removal system is suggested to be installed prior to the conditioner, consulting with your local dealer.

### 3. Check the Water Pressure

- Use a pressure gauge to confirm that the water pressure does not exceed 100 psi. If the water pressure does exceed this limit, install a pressure regulator on the inlet pipe of the unit. The minimum water pressure for a Filter is 30 psi. 60 psi is the optimum operating pressure.

### 4. Well Water Applications - Check Well Pump Flow Rate

- With no water running in the system, open a faucet and let the water run. When the pump motor starts, note the time and close the faucet. When the pump motor stops, record the time in seconds.
- Run water into a measured container (pail with markings, gallon jug, etc.) until the pump starts. Record the number of gallons in the container.
- Divide the gallons of water in the container by the number of seconds the pump ran. This number is your gallons per second. (The number should be less than one.)
- To calculate the gallons per minute, multiply the gallons per second by 60. Repeat this procedure at least three times to obtain the average well pump flow rate.

### 5. Locate a Site for the System

- There are three primary requirements needed for a site: the main water source, an air-gap drain and a grounded electrical connection. Locate the system as close to these items as practical. Drain lines over 50 feet long, may need to be increased in size to allow proper flow.
- Place the system in the desired location. The location should have a level, smooth, and clean surface.

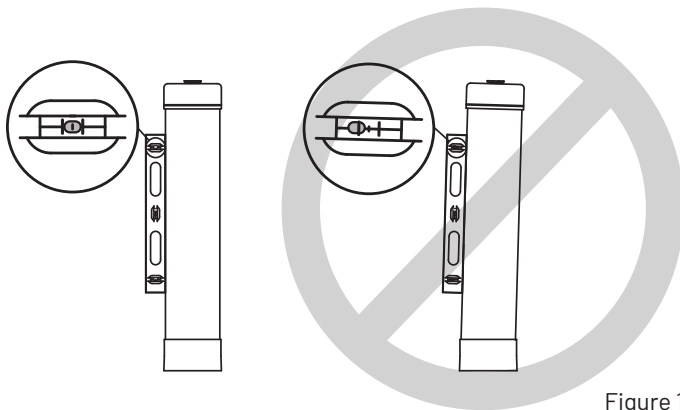

Figure 1

- If the system is located outdoors, protect the unit from direct sunlight. Direct sunlight can damage the fiberglass and other system components. If necessary, build a box or shed. In some installation environments you may choose to partially bury the system. This is done primarily for aesthetics, however this will add stability to the system as well.
- We recommend all systems installed outdoors include the valve weather cover part # 52562.

**Important Note:** Water treatment devices sold to retail consumers in California, accompanied by certain health claims, must be registered by the California State Water Resources Control Board. This product is not certified in the State of California for the purpose of making health claims.

**Important Note:** The well pump flow rate must exceed the recommended backwash flow rate as listed in the Data Chart for the system to clean effectively. Failure to properly backwash the system will result in premature system failure.

**Important Note:** The well pump flow rate must exceed the recommended backwash flow rate as listed in the Data Chart for the system to clean effectively. Failure to properly backwash the system will result in premature system failure.

**Example:** The water measurement is 6.5 gallons and the pump time is 40 seconds.  
 $6.5 \text{ gallons} / 40 \text{ seconds} = 0.1625 \text{ gps}$   
 $0.1625 \text{ gps} \times 60 \text{ seconds} = 9.75 \text{ gpm}$

**For this example, the well pump flow rate is 9.75 gpm.**

\_\_\_\_\_ gallons ÷ \_\_\_\_\_ seconds = \_\_\_\_\_gps [A]

\_\_\_\_\_gps[A] (above) x 60 sec. = \_\_\_\_\_gpm

gps = gallons per second

gpm = gallons per minute

**Important Note:** The system must be level to ensure a proper backwash. Systems that are not installed on a level surface may channel and shorten the mineral life.

**Important Note:** The system can only be installed outdoors in climates that do not reach freezing levels.

## 6. Install the Valve Head

- Remove the cap plug from the tank.
- Lubricate the riser pipe O-ring and tank O-ring with the Dow 111 silicone-based lubricant or equivalent.
- Attach the supplied upper basket to the bottom of the control valve; twist to lock in place. Do not use if water contains any amount of iron.
- Align the upper basket with the riser pipe and slowly lower the control valve onto the riser pipe, using a twisting motion.
- Align the control valve with the tank. Push down on the control valve and continue to turn it clockwise until the valve O-ring seals against the tank (see figure 2).

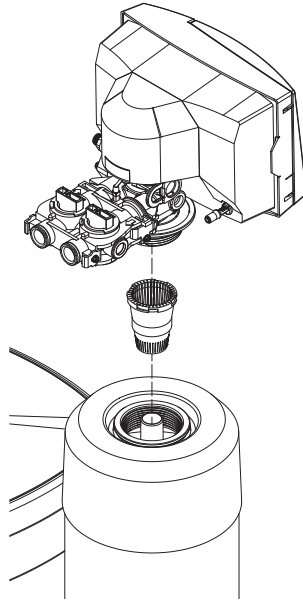

Figure 2

## 7. Turn Off the Water and Drain the Plumbing

- Turn off the water at the meter or the pressure tank.
- To drain the plumbing system, open all faucets in the house and flush the toilets. The water will drain out of the lowest faucet or outlet.
- Do not sweat pipes with water in them or while attached to the system; steam will damage the plastic parts in the valve.
- Do not point the soldering torch directly at the mineral tank or control valve. These composite materials will last a lifetime, but cannot withstand the intense heat from a torch.
- Avoid short connections of pipe between the system and the water heater. If you cannot avoid a short connection, move the system to another location. As a last resort, install a heat trap or check valve. If this causes "water hammer", install a water hammer suppressor.

## 8. Provide Untreated Water for Irrigation or Outdoor Watering

- If available, run an untreated water line to outside faucet or provide a hose connection on untreated line prior to system.

## 9. Create the Plumbing Connections

- Connect the raw water supply to the inlet pipe connection of the yoke. When looking at the front of the unit, the inlet is the pipe connection on the right side of the valve (see figure 3). There is an arrow molded into bypass valve indicating the direction of flow.
- Connect the treated water pipe to the outlet pipe connection on the yoke. When looking at the front of the unit, the outlet is the pipe connection on the left side of the valve (see figure 3). There is an arrow molded into the bypass valve indicating the direction of flow.

**Important Note:** Do not over-tighten the valve to the tank.

**Helpful Tip:** Draining the plumbing will allow air to enter the plumbing system.

**Important Note:** Short connections of pipe may allow hot water to back up into the system. Recommend at least 10 linear feet or three (3) linear meters of pipe between Conditioner and Water Heater.

**Important Note:** The bypass valve is not designed to withstand heat from soldering or twisting from the attached threaded connections.

**Important Note:** Too much weight on the plumbing connections will cause a leak.

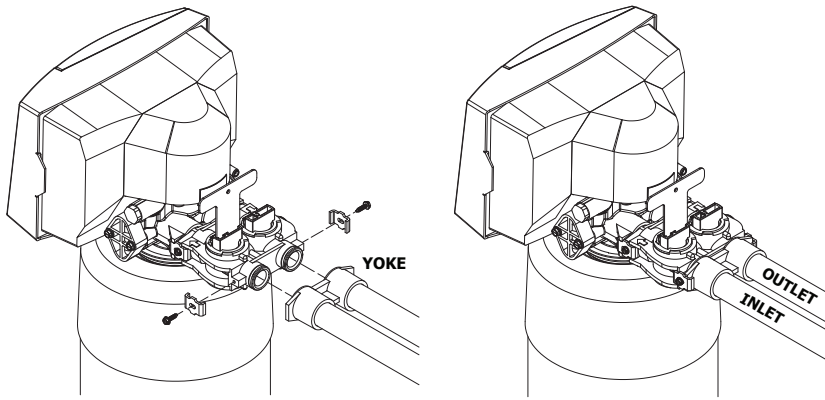

Figure 3

- Support all plumbing connected to the yoke.
- Once the plumbing is complete, connect the yoke to the bypass valve (see figure 3).
- Install the flow control assembly between the bypass and the couplings, as indicated in Figure 3.
- Connect the bypass couplers to the TC-FLT head and tighten all screws.
- When installing on metallic plumbing, connect grounding pipe clamps and cables between the inlet and outlet of the tank
- Ensure that the bypass valve is in bypass position. The valve handles should be perpendicular to the pipes (see figure 4).

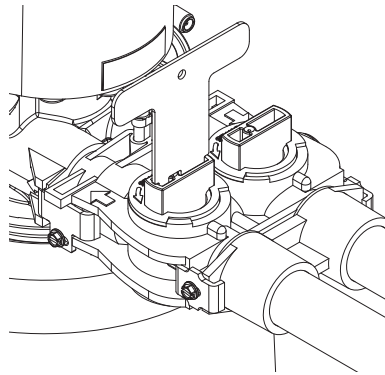

Figure 4

#### 10. Install the Drain Line and Air Gap (air gap not supplied)

- For all drain lines, use at least a 1/2 inch I.D. line.
- Connect the drain line to the drain outlet on back of the valve, opposite the inlet connection (see figure 5). A fitting is require to connect the female pipe thread to the drain line. Run the drain line to the air gap.

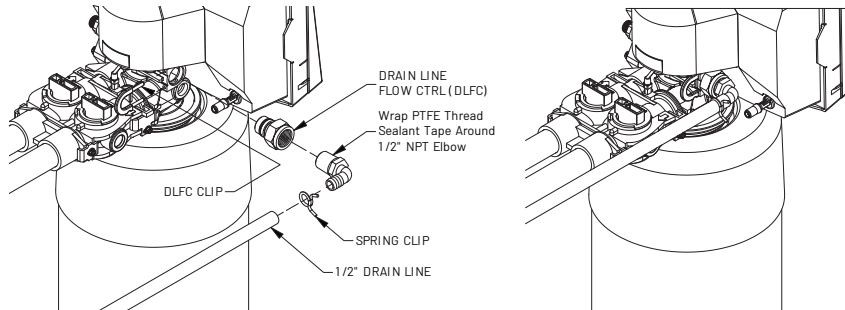

Figure 5

- The air gap should be installed between the end of the drain line and the drain to prevent possible back siphoning (see figure 6).

**Important Note:** Too much weight on the plumbing connections will cause a leak.

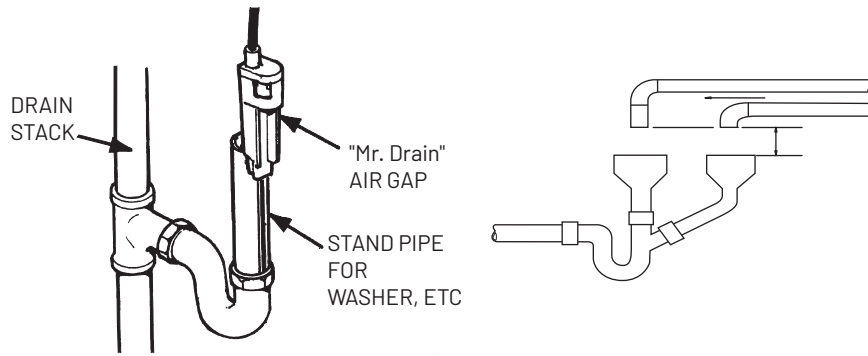

Figure 6

**Important Note:** The air gap should be two times the diameter of the drain line or a minimum of two inches. Please check your local plumbing codes to ensure compliance.

**The air gap must be open and free of obstructions to achieve a proper backwash rate (see figure 6).**

#### 11. Attach the Electrical Connection

- Insert the barrel plug from the DC power supply into the mating jack in the back of the control box.
- Plug the DC power supply into a 110 VAC 60 Hz or 230 VAC 50 Hz outlet.

### SYSTEM START UP

#### 1. Turn on the Water and Check for Leaks

- Close all faucets and turn the water back on at the water meter or pressure tank.
- Check for leaks. If a leak is present, drain the plumbing again before soldering.

#### 2. Flush the Remaining Debris from the System

- Open the cold water faucet on your bathtub.
- Allow the system to flush the remaining dirt and debris into the bathtub, until the water runs clear.
- Open all remaining faucets and allow the plumbing to release any trapped air in the system.
- Close all of the faucets.

#### 3. Open the Bypass Valve

- Move the bypass valve handles to the service position. The valve handles should be parallel to the pipes (see figure 7).
- Open a cold water tap and allow the appliance to flush for 20 minutes or until approximately 100 gallons has passed through the appliance.

**Helpful Tip:** Flushing the system will prevent dirt and debris from entering the valve.

**Important Note:** All air should be purged from the bypass valve. To purge any trapped air from the bypass seal pocket, open and close the bypass valve two (2) to three (3) and allow the water to run from the system.

**Helpful Tip:** It is common for new systems to have some color in the water. The color should disappear after you completely flush the system.

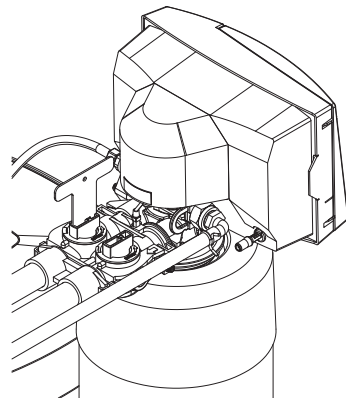

Figure 7

#### 4. Flush the Hot Water Heater

- Run hot water in the bathtub until the water tests soft.
- minutes. Let the solution stand for a minimum of thirty minutes. Run the hot water until the water looks clear and no bleach smell is detected.
- Re-install the post filter.

## **MAINTENANCE REQUIREMENTS**

---

### **Replacing the Filter Media**

The filter media will eventually become exhausted or consumed and will need to be replaced. We recommend replacing or refilling the filter media every 6 months or earlier if necessary. Your RainSoft Dealer can give you specific replacement schedules based on your water usage and incoming water quality. For replacement filter media (part number 14828 and/or 14829), please contact your local RainSoft Dealer.

### **Cleaning the Regeneration Valve**

The regeneration valve body is designed to last a lifetime, but from time to time it may be necessary to clean and lubricate the moving parts. Your water quality and the amount of regenerations necessary will affect this maintenance schedule. Your local RainSoft Dealer is knowledgeable in the different water qualities and will have the necessary parts to complete this service.

## **AN OVERVIEW OF THE REGENERATION PROCESS**

---

Your RainSoft TC Filter performs a periodic regeneration cycle to clean and refresh the media bed. How often it regenerates depends on your water use, incoming water conditions, and several other factors, but one (1) to two (2) regenerations per week can be typical. An automatic regeneration should never occur more than once a day, and the Regen Time is set to occur when you are unlikely to be using water (Default setting is 2:00 AM). Here is an overview of the regeneration process.

### **TC Filter Regen Process:**

#### **Cycle 3: Backwash**

When time for the regen to start - the system will do a 10 second count down, then the valve moves to the backwash position for the start of the actual regeneration of the system. In the backwash position, the drain is in the open position, allowing water in the pressure tank to flow in reverse. With water flowing from the bottom up, lifting and cleaning the media bed inside the pressure tank. This removes any dirt or particles that have accumulated on the top of the mineral bed. During this regeneration, water will flow through the tank flushing dirt or particles to the drain. When using water in the home during this regeneration process, untreated water is available to the house bypassing through the valve until the regeneration process is complete.

#### **CYCLE 4: Slow Rinse (optional)**

Now that the system has completed cycle 3 and backwashed for the set time, the valve moves to the slow rinse position. This position is an optional position and is normally set to zero (0) minutes. In this position, water flows top to bottom, the system continues to slowly rinse the media bed into position.

#### **CYCLE 5: Fast Rinse**

The valve then moves to this final regeneration process cycle 5. Water flows top to bottom, quickly flowing water through the bed for a final fast rinse. This settles the media bed back down and serves as a final cleaning rinse. Upon completion of cycle 5 the Regeneration process is complete.

**NOTE:** The entire regeneration cycle, from backwash to fast rinse, takes about 15 to 45 minutes in most cases. The valve is in automatic bypass during these cycles and untreated water will be supplied into the homes plumbing during this time only if water is in use.

### **When to use the Manual Regeneration Option:**

The TC Control has a manual regeneration mode available "Regen Now." See the "How to Initiate a Manual Regeneration" in this manual on how start a manual regeneration.



## TC DISPLAY

---

The TC Display / Home Screen displays the current conditions of your TC System. Press any button to turn on the display light. The normal operation of the display will scroll between the following information:

- Current Time of Day.
- Regen scheduled at set time: This will display when a regen is triggered to occur, displaying the time scheduled regeneration time.
- ERROR Status: If a system Error is detected, the TC will activate the back light automatically indicating an ERROR is detected. Please review Error and contact your RainSoft dealer for more information.

## TC CONTROL NAVIGATION

---

### Setting the Time of Day

Press any button to activate the TC Display. Press the **Right arrow** button. The SET TIME will scroll, use the **up** or **down** arrow button to adjust the time of day. Press the **Left** or **Right arrow** button to toggle between hours and minutes or to Exit.

## REGENERATION SETTINGS

---

### Changing the Regeneration Time

Press any button to activate the TC Display. Press the **Down arrow** button. The REGEN TIME will scroll, use the up or down arrows to adjust the time of day the regeneration will take place. Press the **Left** or **Right arrow** button to toggle between hours and minutes. Press the **Left arrow** button to advance to Days Between Regen. To Exit press **Left arrow** button to until time is shown.

### Days Between Regen (Days BTW Regen):

Press **Left arrow** button past the Regen Time to get to Days Between Regen setting. This setting will initiate a regen to be scheduled per the amount of days listed. Default is every three (3) Days. Use the up or down arrows to adjust the override settings to list how many days you wish the regens to take place.

### Hours Since Last Regeneration

To see the total hours that have passed since the last regeneration has taken place press the **Left arrow** Button from the home screen. - Last Regen: ## Hrs.

### How to Initiate a Manual Regeneration

Press any key to on the control to wake up the display. Press the Enter / Regen Button to enter Regen Menu.

### The TC will display: Regen Now?: N

- Press the **Up** or **Down arrow** button to change No to Yes. Press the **Enter / Regen** button. The display will start a 10 second count down to begin full regeneration. To cancel manual regeneration, during the 10 second count down, press any button to stop the manual regen. When the count down ends, the Regeneration Process will begin.
- It is best to complete the Regeneration Process fully, however you can step each stage of the Regen process if initiated in error by pressing and holding the **Right arrow** button.

### To initiate a Regen Later?

- Follow the same steps from above, when Regen Now?:N, Press **Enter / Regen** button again to advance to Regen Later?:N. Press the Up or Down button to change No to Yes. Press the Enter /Regen Button.
- The display will return to the home screen. Display will scroll between, the Current Time of Day, Regen at: (Time set). Note this regen later time is set to regen at the normally schedule regen.

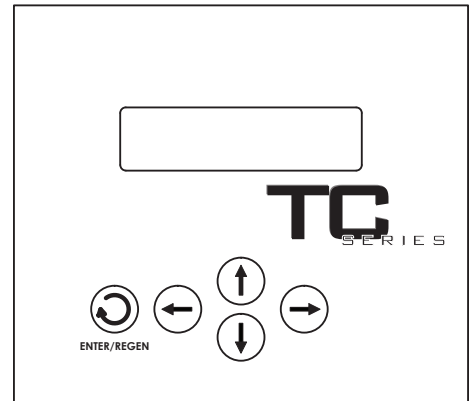

**Important Note:** If you have more than one system, do not set the regenerations for the same time of day. We recommend setting the regenerations at least two hours apart.

## INSTALLER MODE

---

### Programming the TC System

Initial power up of the system, the control should automatically start Installation Mode; scrolling message will appear as "Install Mode": TCM. Follow steps below to setup your system.

To get to Install Mode at any time after installation Press and hold the **Up arrow** until display scrolls "Enter Code." Press the **Up arrow** two (2) times to enter Install mode.

- **Install Mode:** Select system type by using the **Up** or **Down** arrow to change the system type. The types of systems are: TCM (Time Clock Metered), TC (Time Clock), F8 (Specialized Filter System), **FLT (Filter System)**. **Adjust to FLT**
- Press the **Right arrow** to advance to **Model Size:** select model size by using the **Up** or **Down arrow** button. Model sizes listed are in reference to the size of system the control is installed on.
- Press the **Right arrow** button to advance to the **Backwash** setting. The factory setting is five (5) minutes, and the range is five (5) to 30 minutes. Use the **Up** or **Down arrow** button to adjust the setting
- Press the **Right arrow** button to advance to the **Brine and Rinse** setting. The factory setting on FLT mode is 0. The setting can be increased as an option. Use the **Up arrow** button to adjust the setting.
- Press the **Right arrow** button to advance to the **Fast Rinse** setting. The factory setting is five (5) minutes, based on model size. The setting can be increased five (5) to 99 minutes. Use the **Up arrow** button to adjust the setting.
- Press the **Right arrow** button to advance to the Days Between Regeneration (**Days BTW Regen**) setting. The factory setting is three (3) days, and the range is one (1) to seven (7) days. Use the **Up** or **Down arrow** buttons to adjust the setting.
- Press the **Right arrow** button to return to home screen. The TC will save changes and return to the home screen.

**Important Note:** The System Type, Model Size, Media Type are an important settings specific to the system installed. DO NOT change unless instructed to by a RainSoft Professional.

**Important Note:** In most cases Backwash, Brine & Rinse, and Fast Rinse Settings will not need to be adjusted from Factory Settings. Consult your RainSoft Professional if changes are desired.

**Important Note:** When you exit the Customer Settings, the TCM will automatically save any changes that have occurred.

## SYSTEM ERRORS

---

Your system is equipped to alert you for alarm situations: When Alarm is active, your TC will display the Error Message and on the Display.

Contact your RainSoft Dealer if an Error Message is present.

## SYSTEM TESTING

---

To test the functions of your TC Product, example the key pad, the flow meter or motor. Press and hold the **Up arrow** until display scrolls "Enter Code." Press the **Down arrow** two (2) times to enter **E-Test** mode.

- Keypad test: Follow instructions to test, keypad push buttons.
- Flow Meter: Run water through system or press Enter to skip.
- Motor Test: Once the Flow meter test is done the motor will run through each cycle quickly.

Test is complete press right arrow to enter Install Mode. Navigate Right arrow through Install mode to exit.

If test fails press the right button to exit. Or cycle power to return to home screen.

## TROUBLESHOOTING GUIDE

Symptom	Cause	Solution
1. The system fails to regenerate automatically	1. The power supply is plugged into intermittent or dead power source.	1. Connect to a constant power source. 2. Call your RainSoft Dealer for service.
2. The system regenerates at the wrong time	1. The computer Time is not set properly or Regen Time is not set properly. 2. The time is off due to daylight savings. 3. The maximum system capacity has been exceeded.	1. Check and Reset the time of day/hour of time and regeneration. 2. Reset the time of day/hour. 3. Limit water usage until the regeneration is complete.
3. Poor water quality	1. The raw water has changed. 2. The bypass valve is open. 3. The power supply is disconnected.	1. Call your RainSoft Dealer for a new water analysis. 2. Close the bypass valve. 3. Plug in the power supply.
4. Loss of water pressure	1. Low pressure to the unit.	1. Bypass the system. If the problem still exists after bypass, it is not related to a RainSoft product. (Check your water distribution system.) If the problem is resolved after bypass, call your RainSoft Dealer for service.
5. Constant flow to the drain	1. Foreign material in the valve.	1. Call your RainSoft Dealer to clean the valve.

If the troubleshooting guide did not resolve the symptom, please contact your local RainSoft Dealer for service. If you cannot locate your local RainSoft Dealer, please contact RainSoft Customer Service at 1-800-860-7638 or logon to [www.rainsoft.com](http://www.rainsoft.com) for the name and location of your nearest authorized Dealer.

**VALVE EXPLODED VIEW & PARTS LIST**

Item	Quantity	Part No.	Description	Item	Quantity	Part No.	Description
1	1	17863	Composite Valve Body	21	2	17617	C-Injector Plug Assembly
2	1	17864	Spacer End	22	1	17560	3/4" Coupling Adapter Assembly
3	4	17865	Internal Spacer	23	1	17994,18267, 18268,	3.0, 5.0, 8.0 Drain Line Flow Control Assembly
4	5	17866	Internal Seal	24	1	18445	Distributor Tube Retainer O-ring
5	1	18160	Retainer & Down Flow Piston	25	1	51111, 51113, 51114, 51115	Flow Control Assembly
6	1	17557	Composite Bypass Valve	NOT Shown	1	18985	WHITE UPPER DISTRIBUTER BSKT COMP VLV
7	1	17869	End Plug Assembly				
8	5	17870	10-24 x .812 Screw Hex Washer Head				
9	1	17871	Piston Rod				
10	1	17887	Retainer Drain				
11	1	17888	O-ring - 121				
12	1	17889	O-ring - 336				
13	1	17939	1/2" NPT X 1/2" Barb Poly Elbow				
14	1	13329	O-ring - 014				
15	1	17949	Injector Seal				
16	1	17950	Injector Cap				
17	2	17951	10-24 x 1.0 Screw Hex Washer Head				
18	1	18271	Brine Valve Plug				
19	1	17958	O-ring - 015				
20	1	18270	Filter Plug				

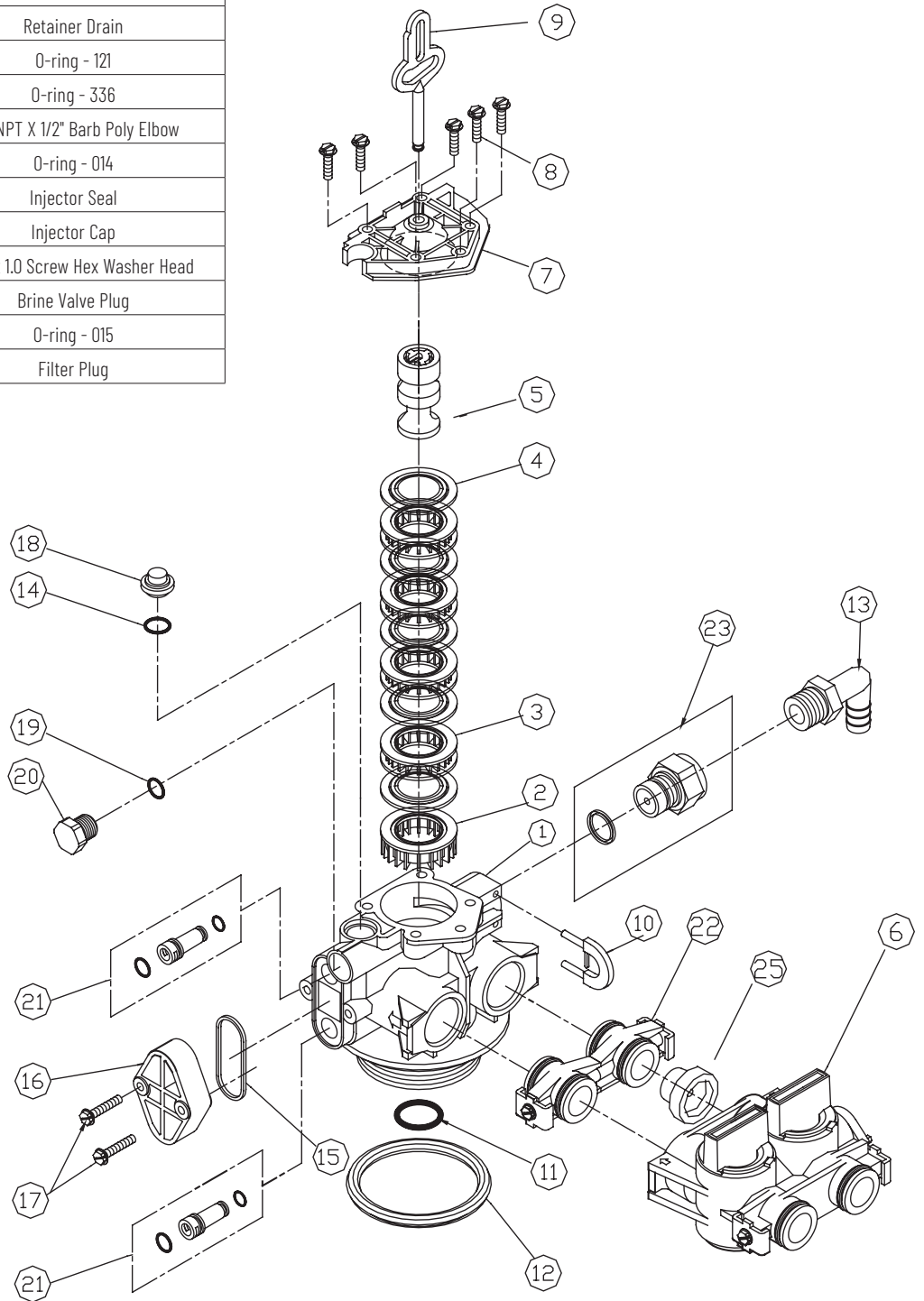

## CONTROL PARTS LIST AND EXPLODED VIEW

Item	Quantity	Part Number	Description
1	1	18265	#4 FLAT WASHER 18-8 S.S.
2	1	51919	SCREW #4-20 X 1/4IN, PHIL PAN PLASTITE
3	1	51827	RAINSOFT USA COUNTED LABEL
4	1	51902	REAR COVER GEN5 & GEN6
5	1	71611	HOLE PLUG .625 DIA HOLE
6	1	52595	TC HYBRID FRONT HOUSING PCB ASSY
6.1	1	52462	GEN6 DOOR TC
6.2	1	51907	SPRING FRONT HOUSING DOOR

Item	Quantity	Part Number	Description
7	1	70873	HOLE PLUG FOR .500 DIA HOLE
8	1	72250	HEYCO SR 4K-4 BUSHING (.500 DIA HOLE)
9	1	51921	RPS SOFTENER VALVE MOTOR ASSY
9.1	1	17501	BRINE GEAR / CAM
10	2	51918	SCREW 1/4-20 X 1IN PHIL PAN SS
11	1	51912	WIRE HARNESS 1 POWER 24 VDC
12	1	52491	GEN6 REAR HOUSING WITH INSERTS
13	1	12280	7/8 SLEEVE CAP

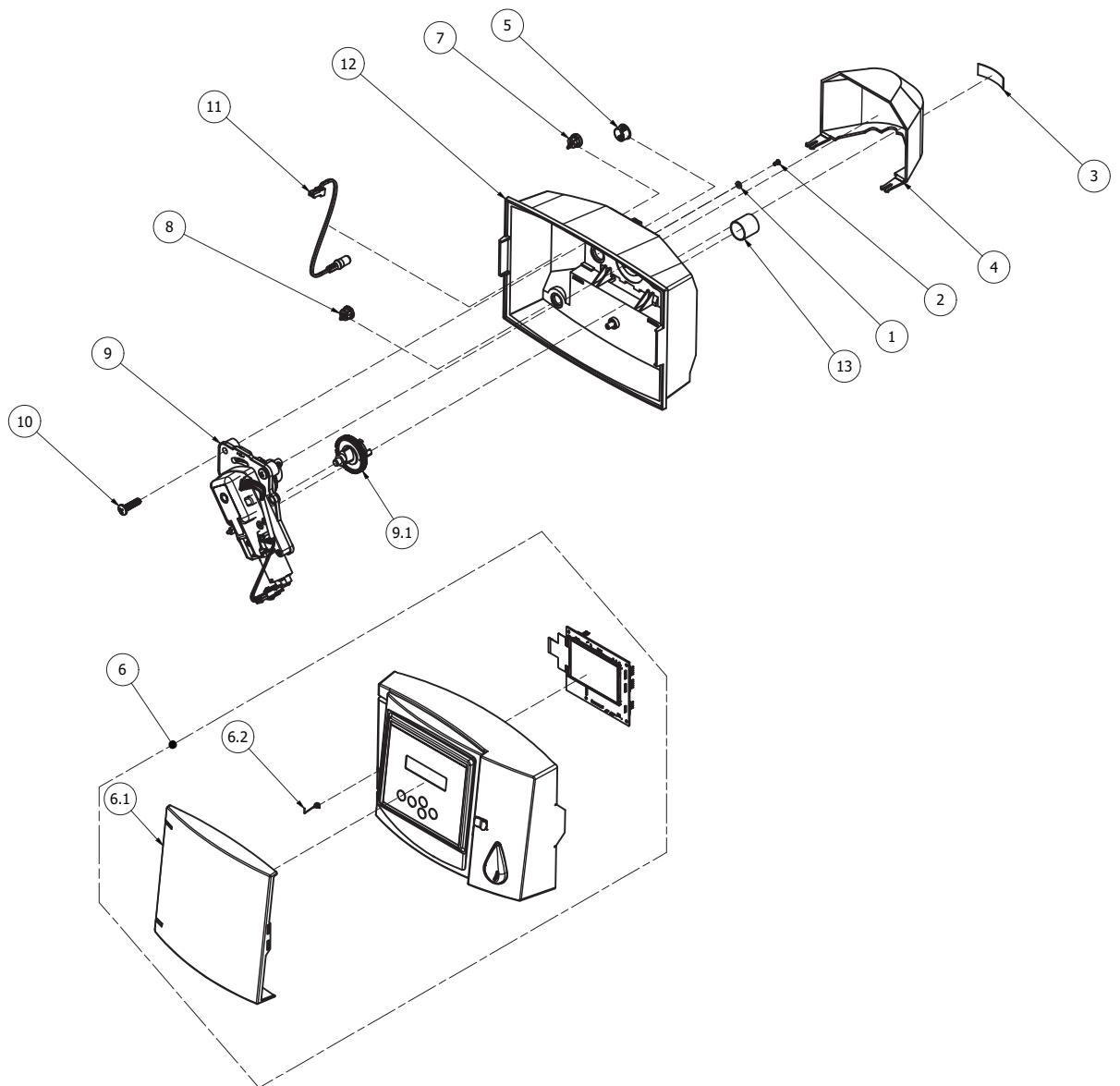

# LIMITED LIFETIME WARRANTY

For as long as you own the equipment

RainSoft Division of Aquion, Inc. believing its

## WATER FILTRATION SYSTEM

to be of exceptional quality, hereby warrants said equipment to its first purchaser at retail as follows:

THE TREATMENT TANK AND VALVE ARE WARRANTED AGAINST DEFECTS IN MANUFACTURE FOR THE LIFETIME OF THE FIRST PURCHASER AT RETAIL.

THE ELECTRICAL PARTS ARE WARRANTED AGAINST DEFECTS IN MANUFACTURE FOR FIVE YEARS AND PRO-RATA WARRANTED FOR AN ADDITIONAL FIVE YEARS.

THE FILTER MEDIA IS NOT WARRANTED. THE FILTER MEDIA SERVICE LIFE IS DEPENDENT ON SPECIFIC WATER CONDITIONS AND USAGE.

This warranty begins at the time the equipment is first connected for use, and is contingent upon the return of a signed owner's registration card.

This warranty does not require replacement of the entire unit. If the equipment does not perform properly, you should request service from the dealer that sold you the equipment. If you are not satisfied, you should notify our Customer Service Manager. If we are not able to arrange local servicing, you should send the defective part(s) (or, if you prefer, send the entire unit,) directly to the manufacturer, freight prepaid, with proof of purchase and a copy of this warranty. The defective part(s) (or entire unit) will either be repaired or new RainSoft part(s) furnished, for a nominal charge to cover labor, handling, packing and the increase, if any, in the retail price of the part(s) since the date of purchase. Genuine RainSoft parts must be used. Failure to use genuine RainSoft parts will void the warranty and certifications.

This warranty does not include labor charges, and does not cover installation, transportation, or any other claims or torts. Some states do not allow the exclusion or limitation of incidental or consequential damages, so parts of the above limitation or exclusion may not apply to you.

This warranty gives you specific legal rights, and you may also have other rights which vary from state to state. You also have implied warranty rights. In the event of a problem with warranty service or performance, you may be able to go to a small claims court, a State court, or a Federal District Court.

This warranty is void if equipment is not installed and operated according to instructions. It does not apply to damage caused by abuse, accident, neglect, freezing, fire, or other abnormal conditions beyond the company's control. This warranty is void on any part from which the manufacturing date has been removed or made illegible.

Benefits will be provided by various types of RainSoft equipment when installed and operated according to the manufacturer's recommendations. Operational, maintenance and replacement requirements are essential for the product to perform as advertised. All claims are based on the best available information at the time of printing. Manufacturer makes no representations as to the suitability of this equipment for a particular application. Buyer relies entirely on the dealer's recommendations in the purchase of this equipment.

Independent RainSoft dealers may include, together with your RainSoft product, a product or component that is not manufactured by RainSoft or their parent company, Aquion, Inc. Any non-RainSoft product may be covered by the manufacturer of that product, and is not covered by the RainSoft warranty. Aquion, Inc. does not warrant that your RainSoft product and the non-RainSoft product will perform properly when used together, and assumes no liability therefore.

RainSoft Division of Aquion, Inc.  
101 S. Gary Avenue  
Roselle, IL 60172 USA

**INSTALLER SPECIFICATION SHEET**

---

Dealer Name:

Phone Number:

Installation Number:

Installation Date:

Model Number:

Serial Number:

Line Pressure: \_\_\_\_\_ (psi)

Iron: \_\_\_\_\_

pH: \_\_\_\_\_

Sulfur: \_\_\_\_\_

Backwash Flow Rate: \_\_\_\_\_ (gpm)

Recommended Regeneration Frequency: \_\_\_\_\_ Days

Recommended Backwash Time: \_\_\_\_\_ (10 minutes minimum)



**Rainsoft, A Division of Aquion | 101 S. Gary Avenue | Roselle, Illinois 60172 | Main: 847.437.9400 | Customer Service : 800.860.7638 | [rainsoft.com](http://rainsoft.com)**

All indicated Pentair trademarks and logos are property of Pentair. Third party registered and unregistered trademarks and logos are the property of their respective owners.

©2024 Pentair. All Rights Reserved.